

Bursa Announcement

Subject : Brand License Agreement between AirAsia Berhad and PT Indonesia AirAsia Extra

Contents:

1. Introduction

AirAsia Berhad (“**AirAsia**” or “the **Company**”) is pleased to announce that it has today entered into a brand license agreement (the “**Agreement**”) with PT Indonesia AirAsia Extra (“**IAAX**”), an Indonesian joint venture company of AirAsia X Berhad (“**AirAsia X**”), in relation to the use of the brand name, trademark and logos of AirAsia X in Indonesia subject to IAAX obtaining an Air Operator’s License issued by the Indonesia Directorate General of Civil Aviation.

2. Details of IAAX

IAAX has already been legally established having successfully obtained both Indonesian Investment Coordinating Board and Indonesian Ministry of Law and Human Rights approvals on 13 August 2013. IAAX shall engage in low-cost, long-haul transportation services under the AirAsia X brand in Indonesia. The current shareholding of the joint venture is set forth as follows:

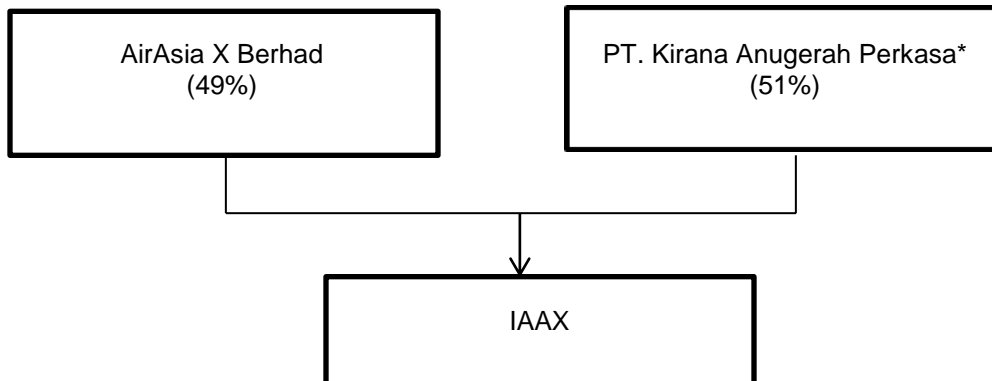

The transaction between IAAX and the Company is deemed a related party transaction by virtue of the facts as specified below:

- a) Tan Sri Dr. Anthony Francis Fernandes (“**Tan Sri Dr. Tony Fernandes**”) and Datuk Kamarudin Bin Meranun (“**Datuk Kamarudin**”) are both Directors and Major Shareholders of the Company whereby Tan Sri Dr. Tony Fernandes’s shareholding in the Company is 0.06% (Direct) and 19.09% (Indirect) and Datuk Kamarudin’s shareholding in the Company is 0.07% (Direct) and 19.09% (Indirect) as at 8 December 2014.

- b) AirAsia X is holding a total of 49% equity stake in IAAX and that both Tan Sri Dr. Tony Fernandes and Datuk Kamarudin are the Directors and Major Shareholders of AAX. Tan Sri Dr. Tony Fernandes' shareholding in AAX is 2.11% (Direct) and 31.59% (Indirect) and Datuk Kamarudin's shareholding in AAX is 8.14% (Direct) and 31.59% (Indirect).

Both Tan Sri Dr. Tony Fernandes and Datuk Kamarudin are referred to as "Related Parties"

3. Salient terms of the Agreement

The terms of the Agreement are substantially similar to the terms of the brand license agreements signed by the Company with each of its airline operating companies and the salient terms are reproduced below:

- a) The brand license fee shall be 1.5% of the Consolidated Revenue per Audited Financial Statements per annum (in USD) for each financial year of IAAX ("**Brand License Fee**"). The Brand License Fee shall be payable in quarterly instalments and within thirty (30) days of invoice.
- b) The term of the Agreement shall be an initial term of five (5) years and may be extended by IAAX subject to mutual agreement of the parties prior to the expiry of the term.
- c) IAAX shall adopt and implement AirAsia's Branding Guidelines, Operational Requirements and Know How, which are the operational processes as well as manuals relating to the low cost business of AirAsia save where the operational requirements of AAX will prevail in relation to requirements of operating low cost long-haul airline services.
- d) IAAX will provide quarterly management report or other information upon request.
- e) IAAX agrees to indemnify the Company for losses suffered due to any default.
- f) The Agreement is governed by Malaysian laws.

4. Rationale for entering into the Agreement

- a) The parties are entering into the Agreement to allow IAAX the use of the AirAsia brand in the same manner and approach as AirAsia X within the AirAsia group of airlines. IAAX is

in need of a brand identity and standard operating procedures to operate as a low cost long-haul carrier in Indonesia. AirAsia together with the experience of an on-going brand agreement with AirAsia X has the necessary intellectual property to address this need.

- b) The Agreement will allow IAAX to operate and be visually recognizable in the same manner as AirAsia X within the AirAsia group of airlines thus enlarging AirAsia's market share across the region. This includes building AirAsia's brand equity through a new fleet, new routes and customer base.
- c) Extending the use of the brand to IAAX will aid in expanding the AirAsia brand not only in a new market segment within Indonesia but also in markets that IAAX may serve which are currently out of AirAsia's 4-hour operating radius.
- d) Since IAAX will pay the Brand License Fee, the Agreement does not only provide the Company a growth in brand reach but also profit from the extension of the brand to IAAX.
- e) The use of the AirAsia brand by IAAX can lead to cross-marketing revenue similar to that between AirAsia and AirAsia X (i.e. sales as a result of consumers traveling to Indonesia via IAAX and onwards to other AirAsia destinations).
- f) IAAX's low cost long-haul model (the same as AirAsia X) can help elevate AirAsia's brand positioning in Indonesia and new market expansions through offerings that IAAX will market.

5. Financial Risks

The financial risks associated with the Agreement are expected to be very limited as the Company does not need to make any investment.

6. Directors' and major shareholders' interests

The Related Parties are deemed interested in the Agreement and they have abstained from all Board and management deliberations in respect of the Agreement.

The Interested Parties' direct and indirect shareholdings in AirAsia as at 8 December 2014 are as set out in the table below:-

	Direct		Indirect*	
	No. of Shares	%	No. of Shares	%
Tan Sri Dr. Anthony Francis Fernandes	1,600,000	0.06	531,212,082	19.09
Datuk Kamarudin bin Meranun	2,000,000	0.07	531,212,082	19.09

Note:

* deemed interested by virtue of Section 6A of the Companies Act, 1965 through a shareholding of more than 15% in Tune Air Sdn Bhd.

Save as disclosed, no other directors and/or major shareholders of AirAsia and/or persons connected with them have any interest, whether directly or indirectly, in the Agreement.

7. Audit Committee's Opinion

The Audit Committee having considered all the relevant factors in respect of the Agreement is of the opinion that entering into the Agreement is in the best interest of the Company and the Agreement is entered under fair, reasonable and on normal commercial terms which are not detrimental to the interest of the minority shareholders, due to the reasons stated in the rationale and considering the limited level of risk exposure mentioned above.

8. Statement by Board of Directors

Save for the Related Parties (who have abstained), the Board having considered all the relevant factors in respect of the Agreement is of the opinion that entering into the Agreement is in the best interest of the Company.

9. Financial effect of the Agreement

This Agreement will not have any material financial impact in the current financial year nor will it have any effect on the share capital and substantial shareholders' shareholdings of AirAsia. It is also not expected to have a material effect on the net assets per share, earnings per share and gearing of AirAsia for this financial year ending 31 December 2014.

10. Approval required

AirAsia does not require the approval of its shareholders or any government authorities to enter into the Agreement.

11. Highest percentage ratio

The highest percentage ratio applicable to this transaction is 2.02% and the highest aggregated percentage ratio for all the transactions between the Company and the Related Parties and/or persons connected with them pursuant to Paragraph 10.12(1) of the Main Market Listing Requirements of Bursa Malaysia Securities Berhad is 2.60%.

12. Total amount transacted for the preceding twelve months

The total amount transacted between the Company and the Related Parties and/or persons connected with them for the preceding twelve (12) months was RM2,805,379.50.

13. Document available for inspection

The Agreement is available for inspection at the registered office of the Company at B-13-15, Level 13, Menara Prima Tower B, Jalan PJU 1/39, Dataran Prima, 47301 Petaling Jaya, Selangor Darul Ehsan, Malaysia during normal business hours from Mondays to Fridays (except public holidays) for a period of 3 months from the date of this announcement.

This announcement is dated 8 December 2014.